

Mounting an autonomously measuring station

By BITT Technology

Mounting an autonomously
measuring station

V2.0
2006-12-17

Content

1.	Mounting an autonomously measuring station	4
1.1	Ground work	4
1.2	Mounting of the standing pipe	4
1.3	Mounting of the RS03/232 probe with the probe cable	6
1.4	Mounting of the unit cabinet on the standing pipe	7
1.5	Mounting of the solar module	7
1.6	Mounting of the GSM antenna	8
1.7	Mounting of the Lightning Protection	8
2.	Wiring of the station	10
1.8	Wiring of the station	10
1.8.1	Sensor cable (S2)	11
1.9	Wiring of the station with an additional Power supply	12
1.9.1	Sensor cable (S2)	13
	Document release	14

1. Mounting an autonomously measuring station

1.1 Ground work

For the fixed installation of the station a strong concrete ground work is essential. Recommended dimension for the ground work: 100cm x 100cm. The depth of the ground work is made accordingly to the frost limit of the ground of this area.



Attention! Should the probe be installed on an external standing pipe (not on the mechanic of the station), there must be provided a blank pipe system in the ground work (in the middle of the ground work).

The length of the blank pipe system should have

such a length that the end stand out 20cm from the upright standing pipe.

Attention! Should further inlets be planned (external additional power supplies) these also must be provided in an own blank pipe system at current now.



By mounting of the probe on an external standing pipe please pay attention to the distance between probe and station to have no impairment of the direction dependence of the probe.

1.2 Mounting of the standing pipe

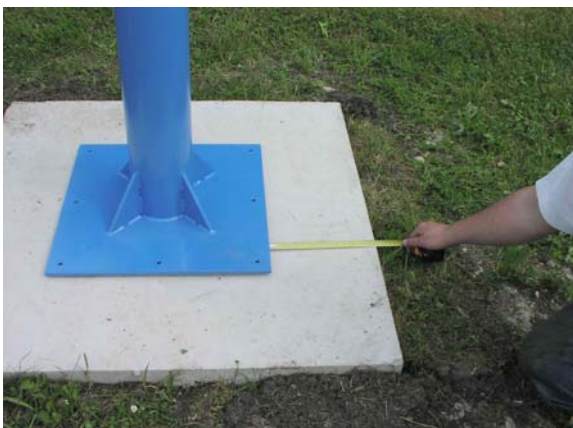

The standing pipe should be fixed in the middle of the ground work.

Attention! Blank pipe is to be conducted through the standing pipe.

Attention!! On the standing pipe are conductor holders for the round conductor. These holders should be on the back side.





The fixing should be made with the heavy duty mounting screw (MKT SZ-S 12/30), which is included in the delivery.



Please along-screw the earthing conductor clip on the back side.



1.3 Mounting of the RS03/232 probe with the probe cable



The cable of the probe is now to be conducted through the blank pipe and to be mounted and connected on the side of the probe connector according to the plan (wire S2).



On the standing pipe the cable is conducted through the end plate. Following the end plate is to be screwed with the standing pipe (pay attention to the sealing).

1.4 Mounting of the unit cabinet on the standing pipe



Mounting carefully the unit cabinet on the mounting pipe and screwing from beneath through the pipe (pay attention to the sealing).



At the appropriate drillings (6x) the two parts are connected with the screws included in the delivery.

1.5 Mounting of the solar module

By mounting of the solar module it is advisable to obey following steps:

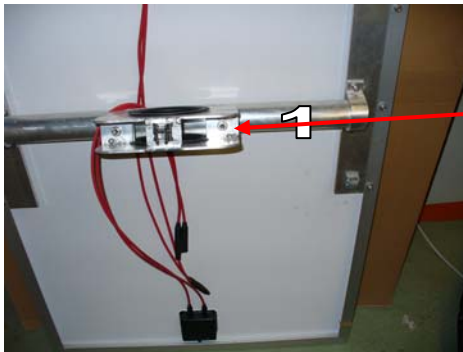

Mounting of the cross carrier (1). Please rotate the cross carrier in an angle of 35 degree.

Please remove the rear half shell of the cross carrier



Subsequently, the module is raised by two persons at the front of the station.

At the back the module is brought by a further person into the correct position and is fastened with the back half shell to the mounting pipe afterwards.



The cross carrier (with the solar panel) should be adjusted to the south direction.

1.6 Mounting of the GSM antenna

Mount the GSM antenna on the top side of the module with the delivered screws.



1.7 Mounting of the Lightning Protection

It is recommended to install a lightning protection system for the Solar Station. All parts (excluding the earthing pipe) are included in the delivery.

Mount the round conductor with the earthing conductor clip and the conductor holders on the case.

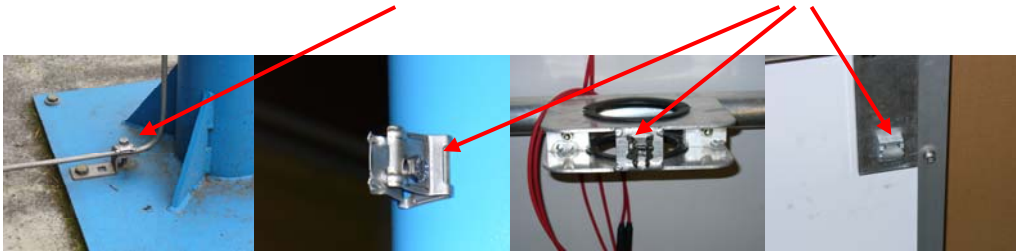

For connecting the conductor on the earthing conductor please use the screw able clip.



For the lightning protection of the solar panel please connect the panel with an additional round conductor and clip.

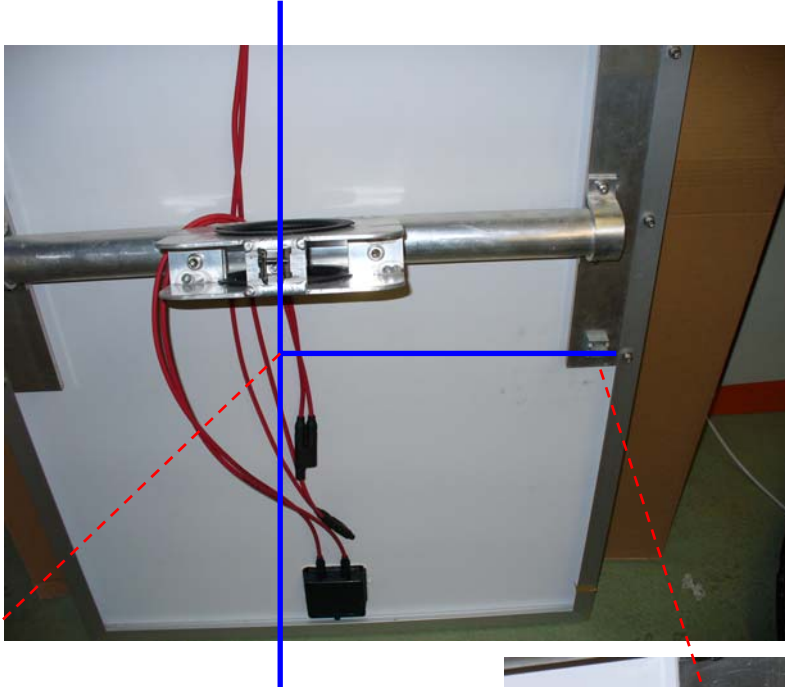

For connecting the two round conductors please use one of this cross terminal clips



On the top the conductor should be 0,4m over the top of the station.

2. Wiring of the station

1.8 Wiring of the station

At first please open all fuse holders

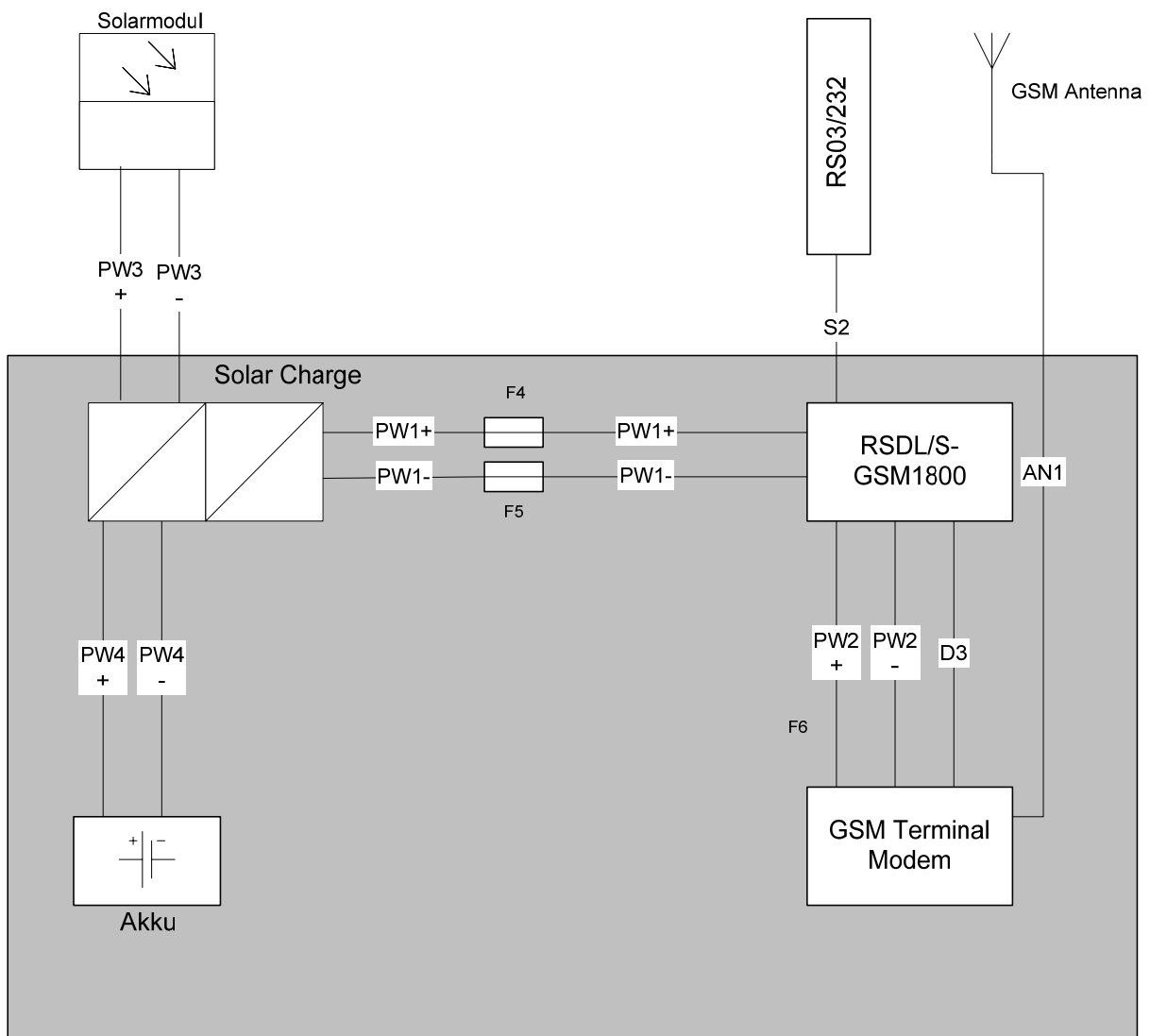
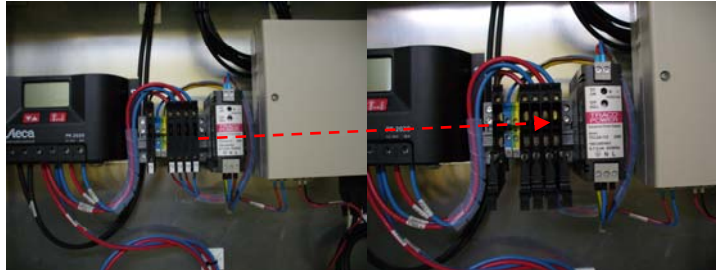

F4_3,15A T
F5_3,15A T

For connecting of the cables following sequence must be kept:

- S2
- D3
- AN1
- PW2
- PW1
- PW4
- PW3

For the connecting and operation of the solar controller see the datasheet.
For the connecting and operation of the terminal modem see the datasheet.

For connecting the battery please remove the heat shrink sleeve (only for transport lock) on the cable end.



Attention!!!
To the correct polarity of the wirings

At last please close all fuse holders

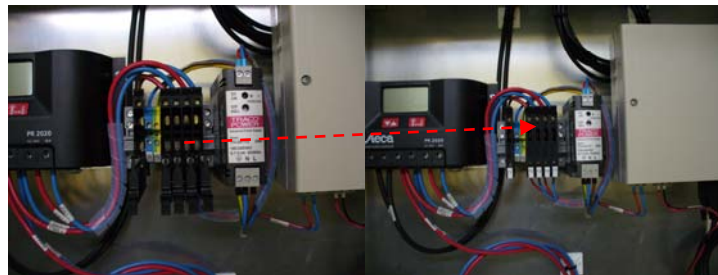

1.8.1 Sensor cable (S2)

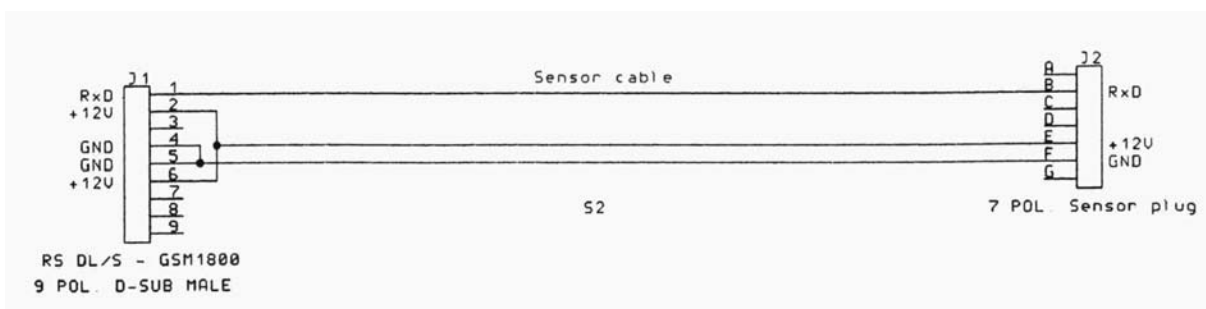

1.9 Wiring of the station with an additional Power supply

At first please open all fuse holders

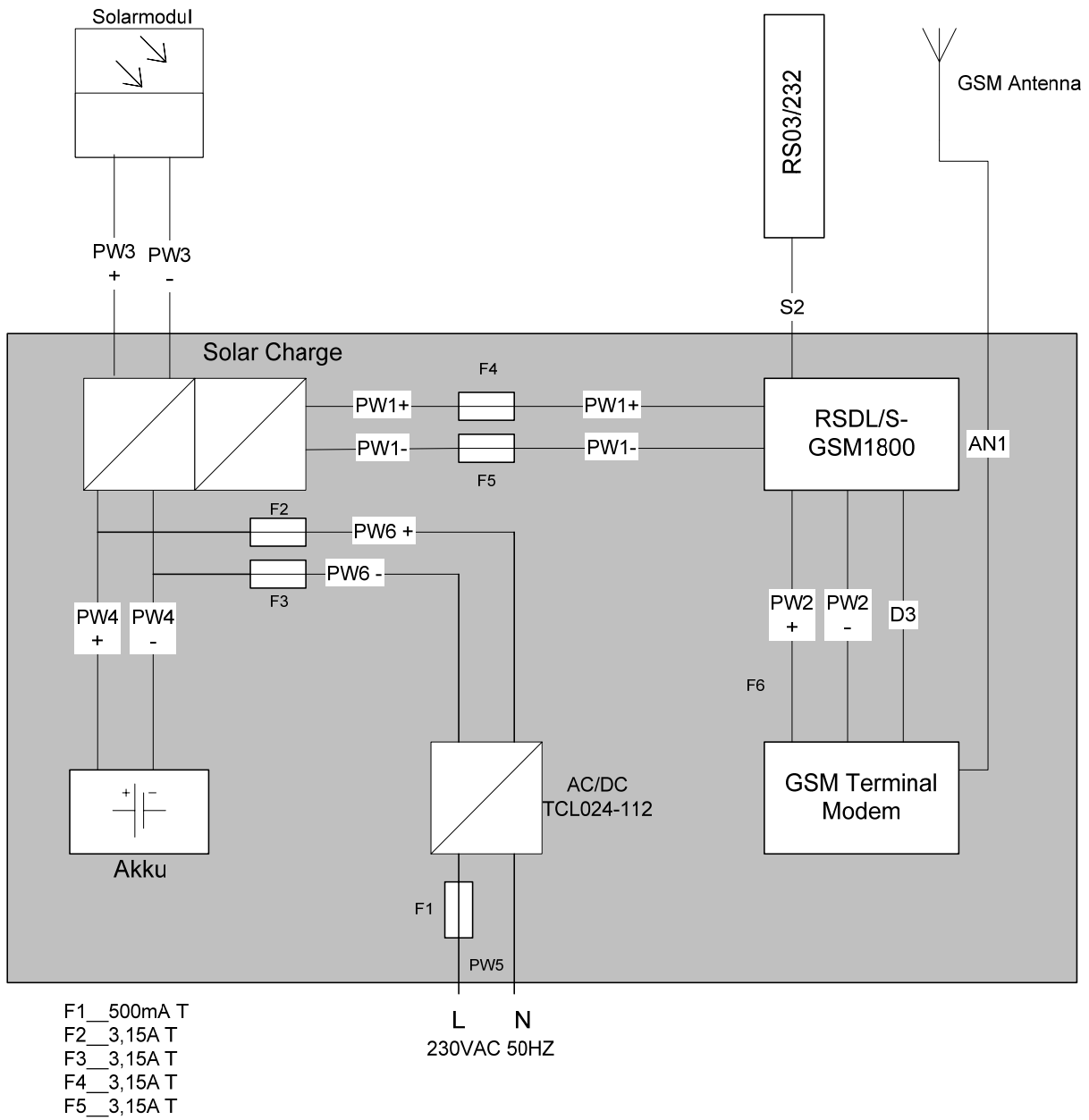
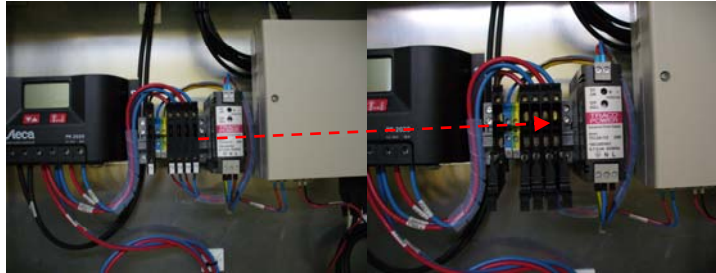

For connecting of the cables following sequence must be kept:

- S2
- D3
- AN1
- PW2
- PW1
- PW4
- PW3
- PW6
- PW5

For the connecting and operation of the solar controller see the datasheet.
For the connecting and operation of the terminal modem see the datasheet.

For connecting the battery please remove the heat shrink sleeve (only for transport lock) on the cable end.



Attention!!!
To the correct polarity of the wirings

At last please close all fuse holders

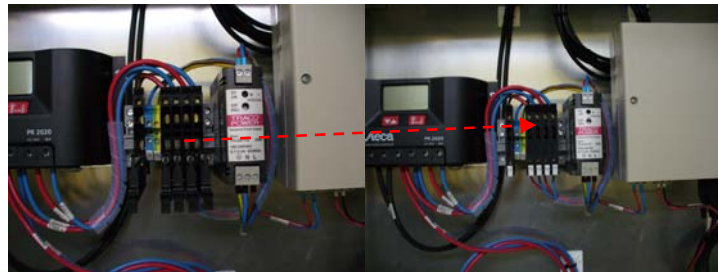

1.9.1 Sensor cable (S2)

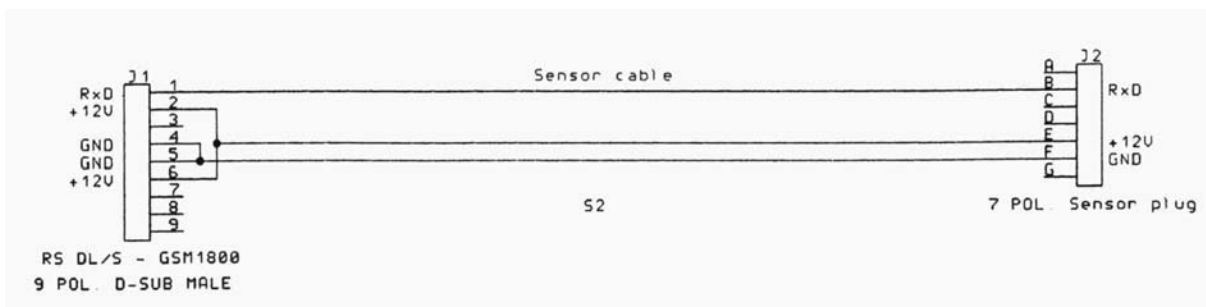

Document release

provided by: Günter Kemminger	date: 22.01.2007
for contents: Günter Kemminger	date: 22.01.2007
Released by: Günter Kemminger	date: 22.01.2007